

# Round Boiling Pans

XP 900

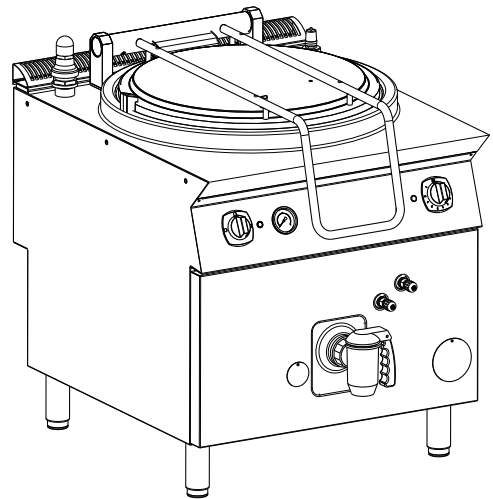

---

EN Installation and operating manual \*



\*Original instructions

59589HB01- 2023.03

## Foreword

 Read the following instructions, including the warranty terms before installing and using the appliance.

**Visit our website [www.electroluxprofessional.com](http://www.electroluxprofessional.com) and open the Support section to:**

---

 Register your product

 Get hints & tips of your product, service and repair information

---

The installation, use and maintenance manual (hereinafter Manual) provides the user with information necessary for correct and safe use of the appliance.

The following must not be considered a long and exacting list of warnings, but rather a set of instructions suitable for improving appliance performance in every respect and, above all, preventing injury to persons and animals and damage to property due to improper operating procedures.

All persons involved in appliance transport, installation, commissioning, use and maintenance, repair and disassembly must consult and carefully read this manual before carrying out the various operations, in order to avoid wrong and improper actions that could compromise the appliance's integrity or endanger people. Make sure to periodically inform the user regarding the safety regulations. It is also important to instruct and update personnel authorised to operate on the appliance, regarding its use and maintenance.

The manual must be available to operators and carefully kept in the place where the appliance is used, so that it is always at hand for consultation in case of doubts or whenever required.

If, after reading this manual, there are still doubts regarding appliance use, do not hesitate to contact the Manufacturer or the authorised Service Centre to receive prompt and precise assistance for better operation and maximum efficiency of the appliance. During all stages of appliance use, always respect the current regulations on safety, work hygiene and environmental protection. It is the user's responsibility to make sure the appliance is started and operated only in optimum conditions of safety for people, animals and property.



### IMPORTANT

- The manufacturer declines any liability for operations carried out on the appliance without respecting the instructions given in this manual.
- The manufacturer reserves the right to modify the appliances presented in this publication without notice.
- No part of this manual may be reproduced.
- This manual is available in digital format by:
  - contacting the dealer or reference customer care;
  - downloading the latest and up to date manual on the web site [www.electroluxprofessional.com](http://www.electroluxprofessional.com);
- The manual must always be kept in an easily accessed place near the appliance. Appliance operators and maintenance personnel must be able to easily find and consult it at any time.

# Contents

A	WARNING AND SAFETY INFORMATION	5
A.1	General information	5
A.2	Personal protection equipment	6
A.3	General safety	6
A.4	Protection devices installed on the appliance	7
A.5	Safety signs to be placed on the appliance or near its area	8
A.6	Reasonably foreseeable improper use	8
A.7	Residual risks	8
A.8	Transport, handling and storage	9
A.9	Installation and assembly	10
A.10	Electrical connection	10
A.11	Water connection	10
A.12	Positioning	10
A.13	Appliance space limitations	11
A.14	Appliance cleaning	11
A.15	Preventive Maintenance	11
A.16	Parts and accessories	11
A.17	Precautions for use and maintenance	11
A.18	Appliance maintenance	12
A.19	Appliance disposal	12
B	WARRANTY TERMS AND EXCLUSIONS	12
C	TECHNICAL DATA	13
C.1	Dataplate position	13
C.2	Appliance and manufacturer's identification data	13
C.3	Gas models	14
D	GENERAL INFORMATION	14
D.1	Introduction	14
D.2	Intended use and restrictions	14
D.3	Testing and inspection	14
D.4	Copyright	14
D.5	Keeping the manual	14
D.6	Recipients of the manual	14
D.7	Definitions	14
D.8	Responsibility	15
D.9	Customer packaging checks	15
D.10	Storage	15
E	INSTALLATION AND ASSEMBLY	15
E.1	Introduction	15
E.2	Customer's responsibilities	15
E.3	Unpacking instructions	16
E.4	Disposal of packing	16
E.5	Joining Appliances	16
E.5.1	Installation On Bridge, Cantilever Frame Or Cement Plinth (depending on the appliance and/or model)	16
E.5.2	Sealing Gaps Between Appliances	16
E.6	Floor fixing (depending on the appliance and/or model)	16
E.7	Gas Connections	16
E.7.1	Introduction	16
E.7.2	Fume exhaust	16
E.7.3	Before connecting	16
E.7.4	Connection (depending on the appliance and/or model)	17
E.7.5	Gas pressure regulator	17
E.7.6	Conversion to another type of gas	17
E.8	Gas appliances regulations	17
E.8.1	Supply pressure check	17
E.8.2	Primary air checking	18
E.8.3	Replacing the main burner nozzle	18
E.8.4	Pilot burner nozzle replacement	18
E.9	Before completing the installation operations	18
E.10	Automatic filling pans	18
E.11	Electrical connections	19
E.11.1	To access the terminal block	19
E.12	Power cable	19
E.13	Safety thermostat	19
E.13.1	Activation	19
E.13.2	Resetting	19
E.13.3	Devices for pressure control (indirect versions only)	20
E.14	Water connection	20
E.15	Water drain	20
F	NORMAL APPLIANCE USE	21
F.1	Characteristics of personnel enabled to operate on the appliance	21
F.2	Basic requirements for appliance use	21

G	INSTRUCTION FOR THE USER.....	21
G.1	General precautions.....	21
G.2	Water filling.....	21
G.3	Cavity water filling (indirect versions only).....	21
	G.3.1 Automatic filling pans (if present).....	21
	G.3.2 Manual filling pans.....	21
G.4	Pressure switch (indirect versions only).....	22
G.5	Gas models.....	22
	G.5.1 Safety thermostat.....	22
G.6	Energy saving.....	22
G.7	At the end of the service.....	22
H	APPLIANCE CLEANING AND MAINTENANCE.....	22
H.1	Care information.....	22
H.2	Informations for maintenance.....	23
H.3	Maintenance intervals.....	23
H.4	Periods of non-use.....	23
H.5	External parts.....	23
H.6	Other surfaces.....	24
H.7	Scale.....	24
H.8	Internal parts (every 6 months).....	24
H.9	Spout greasing.....	24
I	TROUBLESHOOTING.....	24
I.1	Introduction.....	24
I.2	Brief Troubleshooting guide.....	24
J	APPLIANCE DISPOSAL.....	25
J.1	Procedure regarding appliance disposal.....	25

---

## A WARNING AND SAFETY INFORMATION

---

### A.1 General information

To ensure safe use of the appliance and a proper understanding of the manual it is necessary to be familiar with the terms and typographical conventions used in the documentation. The following symbols are used in the manual to indicate and identify the various types of hazards:



#### **WARNING**

Danger for the health and safety of operators.



#### **WARNING**

Danger of electrocution - dangerous voltage.



#### **CAUTION**

Risk of damage to the appliance or the product.



#### **IMPORTANT**

Important instructions or information on the product



Equipotentiality



Read the instructions before using the appliance







Clarifications and explanations

- Only specialised personnel are authorised to operate on the appliance.
- This appliance is to be intended for commercial and collective use, for example in kitchens of restaurants, canteens, hospitals and in commercial enterprises such as bakeries, butcheries, etc., not for continuous mass production of food. Any other use is deemed improper.
- This appliance must not be used by minors and adults with limited physical, sensory or mental abilities or without adequate experience and knowledge regarding its use.
- Do not let children play with the appliance.
- Keep all packaging and detergents away from children.
- Cleaning and user maintenance shall not be made by children without supervision.
- For your safety do not store or use gasoline or other flammable materials, vapours and liquids in the vicinity of this or any other appliance.
- Do not store explosive substances, such as pressurized containers with flammable propellant, in this appliance.
- Refer to the data given on the appliance's data plate for relations with the Manufacturer (e.g. when ordering spare parts, etc.).
- When scrapping the appliance, the marking CE must be destroyed.
- Save these instructions carefully for further consultation by the various operators.

## A.2 Personal protection equipment

Summary table of the Personal Protection Equipment (PPE) to be used during the various stages of the appliance's service life.

Stage	Protective garments 	Safety footwear 	Gloves 	Glasses 	Safety helmet 
Transport	—	●	○	—	○
Handling	—	●	○	—	—
Unpacking	—	●	○	—	—
Installation	—	●	● <sup>1</sup>	—	—
Normal use	●	●	● <sup>2</sup>	—	—
Adjustments	○	●	—	—	—
Routine cleaning	○	●	● <sup>1-3</sup>	○	—
Extraordinary cleaning	○	●	● <sup>1-3</sup>	○	—
Maintenance	○	●	○	—	—
Dismantling	○	●	○	○	—
Scrapping	○	●	○	○	—
<b>Key:</b>					
●	<b>PPE REQUIRED</b>				
○	<b>PPE AVAILABLE OR TO BE USED IF NECESSARY</b>				
—	<b>PPE NOT REQUIRED</b>				

1. During these operations, gloves must be cut-resistant. Failure to use the personal protection equipment by operators, specialized personnel or users can involve exposure to damage to health (depending on the model).

2. During these operations, gloves must be heatproof to protect hands from contact with hot food or hot parts of the appliance and/or when removing hot items from it. Failure to use the personal protection equipment by operators, specialised personnel or users can involve exposure to chemical risk and cause possible damage to health (depending on the model).

3. During these operations, gloves must be suitable for contact with chemical substances used (refer to the safety data sheet of the substances used for information regarding the required PPE). Failure to use the personal protection equipment by operators, specialized personnel or users can involve exposure to chemical risk and cause possible damage to health (depending on the model).

## A.3 General safety

- The appliances are provided with electric and/or mechanical safety devices for protecting workers and the appliance itself.
- Never operate the appliance, removing, modifying or tampering with the guards, protection or safety devices.
- Do not make any modifications to the parts supplied with the appliance.
- Several illustrations in the manual show the appliance, or parts of it, without guards or with guards removed. This is purely for explanatory purposes. Do not use the appliance without the guards or with the protection devices deactivated.

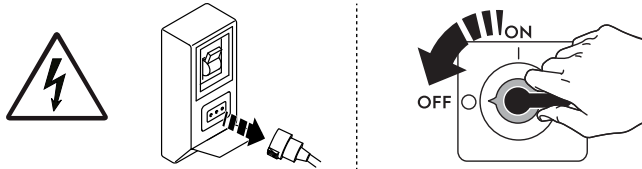

Disconnect the appliance from the power supply before carrying out any installation, assembly, cleaning or maintenance procedure.

- Do not remove, tamper with or make illegible the CE marking, the safety, danger and instruction signs and labels on the appliance.
- Air recirculation must take into account the air necessary for combustion, 2 m<sup>3</sup>/h/kW of gas power, and also the “well-being” of persons working in the kitchen.
- Inadequate ventilation causes asphyxia. Do not obstruct the ventilation system in the place where this appliance is installed. Do not obstruct the vents or ducts of this or other appliances.
- The A-weighted emission sound pressure level does not exceed 70 dB(A).
- Do not use products (even if diluted) containing chlorine (sodium hypochlorite, hydrochloric or muriatic acid, etc.) to clean the appliance or the floor under it.
- Do not spray aerosols in the vicinity of this appliance while it is in operation.
- Never check for leaks with an open flame.
- Install the appliance under conditions of adequate ventilation in order to provide a suitable air change per hour. Make sure that the ventilation system, whatever it is, always remains operational and efficient for the entire period of time during which the equipment is operating.
- Do not obstruct the flow of combustion and ventilation air.
- The following operations have to be carried out by specialised authorised personnel or Customer Care Service provided with all the appropriate personal protection equipment (*A.2 Personal protection equipment*), tools, utensils and ancillary means, who can ask the manufacturer to supply a servicing manual:
  - Installation and assembly
  - Positioning
  - Electrical connection
  - Appliance cleaning, repair and extraordinary maintenance
  - Appliance disposal
  - Work on electrical equipment





#### **A.4 Protection devices installed on the appliance**

##### **Guards**

The appliance has:

- fixed guards (e.g. casings, covers, side panels, etc.), fixed to the appliance and/or frame with screws or quick-release connectors that can only be removed or opened with tools; therefore the user must not remove or tamper with such devices. The Manufacturer declines any liability for damage due to tampering or their non-use;
- interlocked movable guards (door) for access inside the appliance;
- appliance electrical equipment access panels or doors, made from hinged panels openable with tools. The panel or the door must not be opened when the appliance is connected to the power supply.

## A.5 Safety signs to be placed on the appliance or near its area

Prohibition	Meaning
	do not remove the safety devices
	do not use water to extinguish fires (placed on electrical parts)
	Keep the area around the appliance clear and free from combustible materials. Do not keep flammable materials in the vicinity of the appliance
Danger	Meaning
	caution hot surface
	danger of electrocution (shown on electrical parts with indication of voltage)

## A.6 Reasonably foreseeable improper use

Improper use is any use different from that specified in this manual. During appliance operation, other types of work or activities deemed improper and that in general can involve risks for the safety of operators and damage to the appliance are not allowed. Reasonably foreseeable improper use includes:

- lack of appliance maintenance, cleaning and periodical checks;
- structural changes or modifications to the operating logic;
- tampering with the guards or safety devices;
- failure to use personal protection equipment by operators, specialised personnel and maintenance personnel;
- failure to use suitable accessories (e.g. use of unsuitable equipment or ladders);
- keeping combustible or flammable materials, or in any case materials not compatible with or pertinent to the work, near the appliance;
- wrong appliance installation;
- placing in the appliance any objects or things not compatible with its use, or that can damage the appliance, cause injury or pollute the environment;
- climbing on the appliance;
- non-compliance with the requirements for correct appliance use;
- other actions that give rise to risks not eliminable by the Manufacturer.

## A.7 Residual risks

The appliance has several risks that were not completely eliminated from a design standpoint or with the installation of adequate protection devices. Nevertheless, through this manual the Manufacturer has taken steps to inform operators of such risks, carefully indicating the personal protection equipment to be used by them. In order to reduce the risks, provide for sufficient spaces while installing the unit.

To preserve these conditions, the areas around the appliance must always be:

- kept free of obstacles (e.g. ladders, tools, containers, boxes, etc.);
- clean and dry;
- well lit.

For the Customer's complete information, the residual risks remaining on the appliance are indicated below: such actions are deemed improper and therefore strictly forbidden.

<b>Residual risk</b>	<b>Description of hazardous situation</b>
Slipping or falling	The operator can slip due to water, any liquid or dirt on the floor
Burns/abrasions (e.g. heating elements, cold pan, cooling circuit plates and pipes)	The operator deliberately or unintentionally touches some components inside the appliance without using protective gloves.
Electrocution	Contact with live parts during maintenance operations carried out with the electrical panel powered
Crushing or injury	The specialised personnel may not correctly fix the control panel when accessing the technical compartment. The panel could close suddenly.
Tipping of loads	When handling the appliance or the packing containing it, using unsuitable lifting systems or accessories or with the unbalanced load
Chemical	Contact with chemical substances (e.g. detergent, rinse aid, scale remover, etc.) without taking adequate safety precautions. Therefore always refer to the safety cards and labels on the products used.
Sudden closure	The operator for normal appliance use could suddenly and deliberately close the lid/door/oven door (if present, depending on the appliance type).

## **A.8 Transport, handling and storage**

- Transport (i.e. transfer of the appliance from one place to another) and handling (i.e. transfer inside workplaces) must occur with the use of special and adequate means.
- Please refer to indications on packaging for stackability during transport, handling and storage.
- Do not stand under suspended loads during loading or unloading operations. Unauthorized personnel must not enter the work area.
- The weight of the appliance alone is not sufficient to keep it steady.
- For appliance handling, do not lift and anchor it to movable or weak parts such as: casings, electrical raceways, pneumatic parts, etc.
- Do not push or pull the appliance to move it, as it may tip over. Use proper tool to lift the appliance.
- Arrange a suitable area with flat floor for appliance unloading and storage operations.
- Appliance transport, handling, shifting and storage personnel must be adequately instructed and trained regarding the safely use of lifting systems and personal protection equipment suitable for the type of operation carried out.
- When removing the anchoring systems, make sure the stability of the appliance parts does not depend on the anchoring and, therefore, that this operation does not cause the

load to fall off the vehicle. Before unloading the appliance components, make sure all the anchoring systems are removed.

## A.9 Installation and assembly

- The operations described must be carried out in compliance with the current safety regulations and provisions in force in the country of use.
- The plug, if present, must be accessible after positioning the appliance in the place of installation.
- When installing the appliance, make sure gas set and pressure is carried out in compliance with that specified on the data plate.
- The appliance is not suitable for installation outdoors and/or in places exposed to atmospheric agents (rain, direct sunlight, etc.).

## A.10 Electrical connection

- The power supply system must be suitable for the rated current of the connected appliance; the connection must be carried out in compliance with the regulations and provisions in force in the country of use.
- The information regarding the appliance power supply voltage and frequency is given on the data plate.
- Install between the power cable and the electric line a differential thermal-magnetic switch suitable for the absorption specified on the data plate, with contact gap enabling complete disconnection in category III overvoltage conditions and complying with the regulations in force.
- If the power cable is damaged or too short, it must be replaced by the Customer Care Service or in any case by specialised personnel, in order to prevent any risk.
- The manufacturer declines any liability for damage or injury resulting from breach of the above rules or non-compliance with the electrical safety regulations in force in the country where the appliance is used.
- Verify that a safety circuit breaker is installed between the power cable of the appliance and the mains electric line. The contact opening max. distance and leakage current must comply with the local safety regulations.
- If present, connected the appliance to the equipotential protection circuit .

## A.11 Water connection

- **Water connection must be carried out in compliance with the regulations and provisions in force with the country.**
- The appliance must be supplied with drinking water at a pressure of 1.5 — 3 bar.



### **WARNING**

The manufacturer declines any liability if the safety regulations are not respected.



### **NOTE!**

**Only for Australia:** The appliance shall be installed in accordance with AS / NZS 3500.1 and AS / NZS 3500.2 standards.

## A.12 Positioning

- Install the appliances, taking all the safety precautions required for this type of operation, also respecting the relevant fire-prevention measures.

- Prevent the areas where the appliance is installed to be polluted with corrosive substances (chlorine, etc.). The manufacturer declines any liability for corrosive effects due to external causes.
- The appliance can be installed separately or combined only with other appliances of the same range.

### **A.13 Appliance space limitations**

- The appliances are not suitable for recess-mounting. Leave a space of at least 100 between the appliance and side walls and 100 from the rear wall, or in any case an adequate space to enable subsequent servicing or maintenance operations.
- Maintain a distance of at least 250 mm between the appliance and any combustible walls.

### **A.14 Appliance cleaning**

- Do not touch the appliance with wet hands or feet or when barefoot.
- Put the appliance in safe conditions before starting any cleaning operation.
- Do not allow oil or grease to come into contact with plastic parts. Do not allow dirt, fat, food or other residuals to form deposits on the appliance.
- Respect the requirements for the various routine and extraordinary maintenance operations. Non-compliance with the instructions can create risks for personnel.
- Do not spray water or use water jets, steam cleaner or high pressure cleaner.

### **A.15 Preventive Maintenance**

In order to ensure the safety and performance of your equipment, it is recommended that service is undertaken by Electrolux Professional authorised engineers every 12 months, in accordance with Electrolux Professional Service Manuals. Please contact your local Electrolux Professional Service Centre for further details.

### **A.16 Parts and accessories**

Use only original accessories and/or spare parts. Failure to use original accessories and/or spare parts will invalidate the original manufacturer warranty and may render the appliance not compliant with the safety standard.

### **A.17 Precautions for use and maintenance**

- Risks mainly of a mechanical, thermal and electrical nature exist in the appliance. Where possible the risks have been neutralised:
  - directly, by means of adequate design solutions.
  - indirectly by using guards, protection and safety devices.
- Any anomalous situations are signalled on the control panel display.
- During maintenance several risks remain, as these could not be eliminated, and must be neutralised by adopting specific measures and precautions.
- Do not carry out any checking, cleaning, repair or maintenance operations on moving parts. Workers must be informed of this prohibition by means of clearly visible signs.
- Make sure to periodically check correct operation of all the safety devices and the insulation of electrical cables, which must be replaced if damaged.

In case of a significant anomaly (e.g. short circuits, wires coming out of the terminal block, motor breakdowns, worn electrical cable sheathing, etc.) the operator for normal appliance use must:

- immediately deactivate the appliance and disconnect all the supplies (electricity, gas, water).

## A.18 Appliance maintenance

- The inspection and maintenance intervals depend on the actual appliance operating conditions and ambient conditions (presence of dust, damp, etc.), therefore precise time intervals cannot be given. In any case, careful and periodical appliance maintenance is advisable in order to minimise service interruptions.
- It is advisable to stipulate a preventive and scheduled maintenance contract with the Customer Care Service.
- Put the appliance in safe conditions before starting any maintenance operation.
- To guarantee appliance efficiency and correct operation, periodical maintenance must be carried out according to the instructions given in the manual.

## A.19 Appliance disposal

- Make the appliance unusable by removing the power cable and any compartment closing devices, to prevent the possibility of someone becoming trapped inside.

---

## B WARRANTY TERMS AND EXCLUSIONS

---

If the purchase of this product includes warranty coverage, warranty is provided in line with local regulations and subject to the product being installed and used for the purposes as designed, and as described within the appropriate equipment documentation.

Warranty will be applicable where the customer has used only genuine spare parts and has performed maintenance in accordance with Electrolux Professional user and maintenance documentation made available in paper or electronic format.

Electrolux Professional strongly recommends using Electrolux Professional approved cleaning, rinse and descaling agents to obtain optimal results and maintain product efficiency over time.

The Electrolux Professional warranty does not cover:

- service trips cost to deliver and pick up the product;
- installation;
- training on how to use/operate;
- replacement (and/or supply) of wear and tear parts unless resulting from defects in materials or workmanship reported within one (1) week from the failure;
- correction of external wiring;
- correction of unauthorized repairs as well as any damages, failures and inefficiencies caused by and/or resulting from:
  - insufficient and/or abnormal capacity of the electrical systems (current/voltage/frequency, including spikes and/or outages);
  - inadequate or interrupted water supply, steam, air, gas (including impurities and/or other that does not comply with the technical requirements for each appliance);
  - plumbing parts, components or consumable cleaning products that are not approved by the manufacturer;

- customer's negligence, misuse, abuse and/or non-compliance with the use and care instructions detailed within the appropriate equipment documentation;

- improper or poor: installation, repair, maintenance (including tampering, modifications and repairs carried out by third parties not authorized) and modification of safety systems;

- Use of non-original components (e. g.: consumables, wear and tear, or spare parts);

- environment conditions provoking thermal (e. g. overheating/freezing) or chemical (e. g. corrosion/oxidation) stress;

- foreign objects placed in- or connected to- the product;

- accidents or force majeure;

- transportation and handling, including scratches, dents, chips, and/or other damage to the finish of the product, unless such damage results from defects in materials or workmanship and is reported within one (1) week of delivery unless otherwise agreed;

- product with original serial numbers that have been removed, altered or cannot be readily determined;

- replacement of light bulbs, filters or any consumable parts;

- any accessories and software not approved or specified by Electrolux Professional.

**Electrolux Professional warranty will be void and manufacturer shall have no liability related thereto in case of any modification of the product or related hardware/software/programming.**

Warranty does not include scheduled maintenance activities (including the parts required for it) or the supply of cleaning agents unless specifically covered within any local agreement, subject to local terms and conditions.

Check on Electrolux Professional website the list of authorized customer care.

## C TECHNICAL DATA

### C.1 Dataplate position



#### IMPORTANT

This instruction manual contains information relevant to various appliances. See the dataplate located under the control panel to identify the appliance (see fig. below).

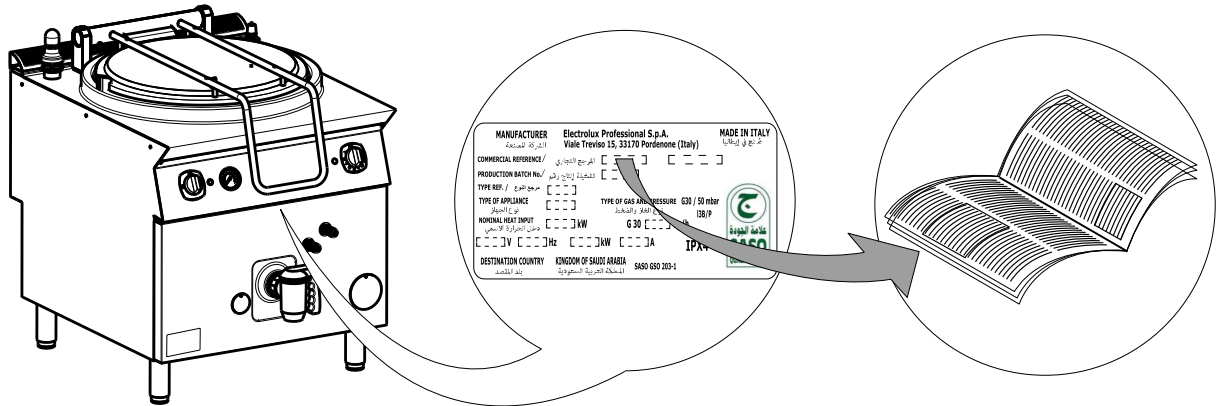

#### IMPORTANT

When installing the appliance, make sure the electrical connection is carried out in compliance with that specified on the data plate.

### C.2 Appliance and manufacturer's identification data

The data plate gives the product identification and technical data.

An example of the marking or data plate on the appliance is given below:

<b>MANUFACTURER</b> الشركة المصنعة	<b>Electrolux Professional S.p.A.</b> Viale Treviso 15, 33170 Pordenone (Italy)	<b>MADE IN ITALY</b> صنعت في إيطاليا
<b>COMMERCIAL REFERENCE /</b> المرجع التجاري	[ ] [ ] [ ] [ ] [ ] [ ] [ ] [ ]	
<b>PRODUCTION BATCH No./</b> تشغيل إنتاج رقم	[ ] [ ] [ ] [ ]	
<b>TYPE REF. /</b> مرجع النوع	[ ] [ ] [ ] [ ]	
<b>TYPE OF APPLIANCE</b> نوع الجهاز	[ ] [ ] [ ] [ ]	<b>TYPE OF GAS AND PRESSURE</b> G30 / 50 mbar نوع الغاز والضغط I3B/P
<b>NOMINAL HEAT INPUT</b> دخل الحرارة الاسمي	[ ] [ ] [ ] kW	G 30 [ ] [ ] kg/h
[ ] [ ] [ ] V [ ] [ ] Hz [ ] [ ] [ ] kW [ ] [ ] [ ] A		<b>IPX4</b>
<b>DESTINATION COUNTRY</b> بلد المقصد	<b>KINGDOM OF SAUDI ARABIA</b> المملكة العربية السعودية	<b>SASO GSO 203-1</b>

The meaning of the various information given on it is listed below:

Commercial reference	Commercial Model and Product Number Code
Production batch No.	Serial number
Type ref.	Certification code
Type of appliance	Flue construction
Nominal heat input	Gas power input
V	Voltage
Hz	Power supply frequency
kW	Electrical power input
A	Absorbed current
SASO GSO 203-1	Gas safety standard
IP **	Dust and water protection rating
I3B/P	Gas category
Electrolux Professional SpA Viale Treviso 15 33170 Pordenone Italy	Manufacturer

## C.3 Gas models

Table /1a

TYPE	Factory Model	Power supply voltage	Electrical power absorbed	Frequency	Phases	Power supply cable section <sup>1</sup>
		V	kW	Hz	Nr	mm <sup>2</sup>
N9PG 800 mm	+9NNATBAMEI	220 - 230	0.1	60	1+N	1
N9PG 800 mm	+9NNCTBAMEI +9NNCTBAMEB					
N9PG 800 mm	+9NNETBAMEB +9NNETBAMEI +9NNETBAMEC					
N9PG 800 mm	+9NNDTBAMEI					
N9PG 800 mm	+9NNFTBAMEI +9NNFTBAMEC					

1. minimum recommended

Table /1b

TYPE	Factory Model	Pot capacity	Minimum pot capacity for proper working	Cavity capacity (min / max)	Connection ISO 7/1 BS/P connection	Nominal heat output
		Lt	Lt	Lt	ø	kW
N9PG 800 mm	+9NNATBAMEI	60	20	11 / 14	1/2"	14
N9PG 800 mm	+9NNCTBAMEI +9NNCTBAMEB	100	33	17 / 19		21
N9PG 800 mm	+9NNETBAMEB +9NNETBAMEI +9NNETBAMEC	150	50	20 / 22		24
N9PG 800 mm	+9NNDTBAMEI	100	-	-		
N9PG 800 mm	+9NNFTBAMEI +9NNFTBAMEC	150	-	-		

## D GENERAL INFORMATION



### WARNING

Refer to "*Warning and Safety Information*".

### D.1 Introduction

This manual contains information relevant to various appliances. The product images in this guide are only an example.

The drawings and diagrams given in the manual are not in scale. They supplement the written information with an outline, but are not intended to be a detailed representation of the appliance supplied.

The numerical values given on the appliance installation diagrams refer to measurements in millimeters and/or inches.

### D.2 Intended use and restrictions

This appliance is designed for cooking food. It is intended for collective use.

Any other use is deemed improper.



#### NOTE!

The manufacturer declines any liability for improper use of the product.

### D.3 Testing and inspection

Our appliances have been designed and optimized, with laboratory testing, in order to obtain high performance and efficiency.

Passing of the tests (visual inspection - gas/electrical test - functional test) is guaranteed and certified by the specific enclosures.

### D.4 Copyright

This manual is intended solely for consultation by the operator and can only be given to third parties with the permission of Electrolux Professional company.

### D.5 Keeping the manual

The manual must be carefully kept for the entire life of the appliance, until scrapping. The manual must stay with the appliance in case of transfer, sale, hire, granting of use or leasing.

### D.6 Recipients of the manual

This manual is intended for:

- the carrier and handling personnel;
- installation and commissioning personnel;
- the employer of appliance users and the workplace manager;
- operators for normal appliance use;
- specialised personnel - Customer Care service (see service manual).

### D.7 Definitions

Listed below are the definitions of the main terms used in the manual. It is advisable to read them carefully before use.

Operator	appliance installation, adjustment, use, maintenance, cleaning, repair and transport personnel.
Manufacturer	Electrolux Professional SpA or any other service centre authorised by Electrolux Professional SpA.

Operator for normal appliance use	an operator who has been informed and trained regarding the tasks and hazards involved in normal appliance use.
Customer Care service or specialised personnel	an operator instructed/trained by the Manufacturer and who, based on his professional and specific training, experience and knowledge of the accident-prevention regulations, is able to appraise the operations to be carried out on the appliance and recognise and prevent any risks. His professionalism covers the mechanical, electrotechnical and electronics fields etc.
Danger	source of possible injury or harm to health.
Hazardous situation	any situation where an operator is exposed to one or more hazards.
Risk	a combination of probabilities and risks of injury or harm to health in a hazardous situation.
Protection devices	safety measures consisting of the use of specific technical means (guards and safety devices) for protecting operators against risks.
Guard	an element of a appliance used in a specific way to provide protection by means of a physical barrier.
Safety device	a device (other than a guard) that eliminates or reduces the risk; it can be used alone or in combination with a guard.
Customer	the person who purchased the appliance and/or who manages and uses it (e. g. company, entrepreneur, firm).
Electrocution	an accidental discharge of electric current on a human body.

## D.8 Responsibility

### The Manufacturer declines any liability for damage and malfunctioning caused by:

- non-compliance with the instructions contained in this manual;
- repairs not carried out in a workmanlike fashion, and replacements with parts different from those specified in the spare parts catalogue (the fitting and use of non-original spare parts and accessories can negatively affect appliance operation and invalidates the original manufacturer warranty);
- operations carried out by non-specialised personnel;
- unauthorized modifications or operations;
- missing, lack or inadequate maintenance;

- improper appliance use;
- unforeseeable extraordinary events;
- use of the appliance by uninformed and / or untrained personnel;
- non-application of the current provisions in the country of use, concerning safety, hygiene and health in the workplace.

The Manufacturer declines any liability for damage caused by arbitrary modifications and conversions carried out by the user or the Customer.

The employer, workplace manager or service technician are responsible for identifying and choosing adequate and suitable personal protection equipment to be worn by operators, in compliance with regulations in force in the country of use.

The Manufacturer declines any liability for inaccuracies contained in the manual, if due to printing or translation errors.

Any supplements to the installation, use and maintenance manual the Customer receives from the Manufacturer will form an integral part of the manual and therefore must be kept together with it.

## D.9 Customer packaging checks

- The forwarder is responsible for the goods during transport and delivery.
- Make a complaint to the forwarder in case of visible or hidden damage.
- Specify any damage or shortages on the dispatch note.
- The driver must sign the dispatch note: the forwarder can reject the claim if the dispatch note is not signed (the forwarder can provide the necessary form).
- For hidden damage or shortages becoming apparent only after unpacking, request the forwarder for inspection of the goods within and no later than 15 days after delivery.

### After packaging checks

1. Remove the packaging.  
Take care when unpacking and handling of the appliance to not cause any shocks on itself.
2. Keep all the documentation contained in the packaging.

## D.10 Storage

The appliance and/or its parts must be stored and protected from damp, in a non-aggressive place, free of vibrations and with room temperatures between 5°C and 50°C.

The place where the appliance is stored must:

- can take the appliance load,
- have a flat support surface to avoid deforming the appliance or damage to the support feet.

# E INSTALLATION AND ASSEMBLY

## E.1 Introduction



### WARNING

Refer to “Warning and Safety Information”.

To ensure correct operation of the appliance and maintain safe conditions during use, carefully follow the instructions given in this chapter.

Check and, if necessary, level the appliance after positioning. Incorrect levelling can cause appliance malfunctioning.



### CAUTION

Keep the ventilation openings in the appliance casing or in the installation structure free of any obstructions.



### CAUTION

Before moving the appliance make sure the load bearing capacity of the lifting equipment used is suitable for its weight.

## E.2 Customer's responsibilities

The tasks and works required of the Customer are:

- check the floor planarity on which the appliance is placed;
- arrange an earthed power socket of suitable capacity for the input specified on the data plate;
- prearrange a high-sensitivity manual-reset magneto-thermal circuit-breaker;
- prearrange a device lockable in the open position for the connection to the power supply.
- install a rapid gas shutoff valve ahead of each individual appliance (depending on the model). Install the valve in an easily accessed place.

**NOTE!**

For information regarding the electrical connection, refer to "A.10 *Electrical connection*".

**E.3 Unpacking instructions**



Unpack the appliance carrying out the following operations:

- if present, cut the straps and remove the protective film, taking care not to scratch the surface if scissors or blades are used;
- if present, remove the cardboard top, the polystyrene corners and the vertical protection pieces;
- for appliances with stainless steel surfaces, remove the protective film very slowly without tearing it, to avoid leaving glue stuck to the surface;
- should this happen, remove the traces of glue with a non-corrosive solvent, rinsing it off and drying thoroughly;
- it is advisable to go over all the stainless steel surfaces with a rag soaked in paraffin oil in order to create a protective film.

**E.4 Disposal of packing**

The packing must be disposed of in compliance with the current regulations in the country where the appliance is used. All the packing materials are environmentally friendly.

They can be safely kept, recycled, or burned in an appropriate waste incineration plant. Recyclable plastic parts are marked as follows:

 PE	<b>Polyethylene</b> <ul style="list-style-type: none"> <li>• Outer wrapping</li> <li>• Instructions bag</li> </ul>
 PP	<b>Polypropylene</b> <ul style="list-style-type: none"> <li>• Straps</li> </ul>
 PS	<b>Polystyrene foam</b> <ul style="list-style-type: none"> <li>• Corner protectors</li> </ul>

The parts in wood and cardboard can be disposed of, respecting the current regulations in the country where the appliance is used.

**E.5 Joining Appliances**

1. Undo the 4 fixing screws and remove the control panels of the appliances (Fig.1A);
2. Remove the fixing screw nearest the control panel, from each side to be joined (Fig.1B);
3. Bring the appliances together and turn the feet to level them until the tops match (Fig.1D);
4. Turn one of the two plates inside the appliances 180°C (Fig.1C);

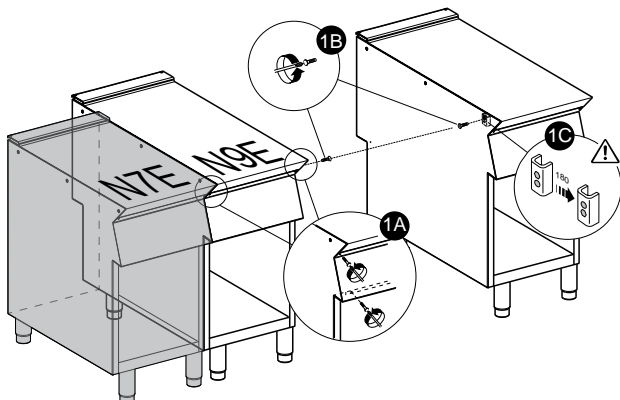

5. From inside the control panel of the same appliance, join them at the front side, screwing one M5x40 Hex Head screw (supplied) on the opposite insert (Fig.1E);

6. From the rear of the appliances, insert the coupling plate (provided) in the side slots on the back panels;
7. Secure the plate with two flat head M5 screws provided (Fig.1F).

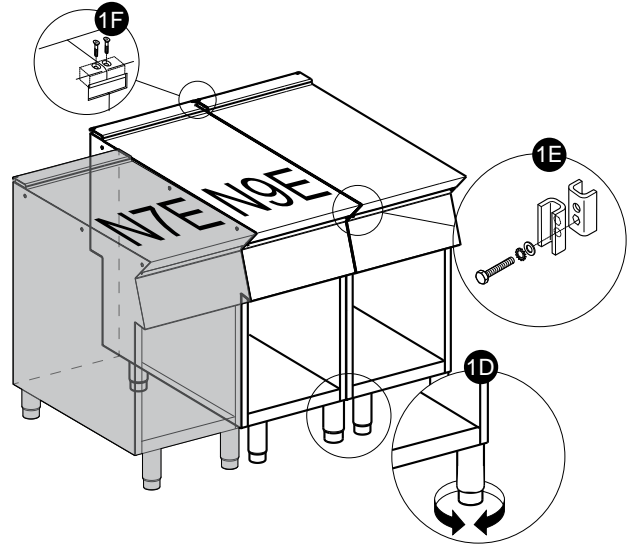
**E.5.1 Installation On Bridge, Cantilever Frame Or Cement Plinth (depending on the appliance and/or model)**

Carefully follow the instructions enclosed with the corresponding accessory. Follow the instructions supplied with the optional product chosen.

**E.5.2 Sealing Gaps Between Appliances**

Follow the instructions supplied with the optional sealing paste pack.

**E.6 Floor fixing (depending on the appliance and/or model)**

To avoid accidental tipping of built-in half-module appliances installed separately, fix them to the floor.

The instructions are enclosed with the corresponding accessory (F206136).

**E.7 Gas Connections****E.7.1 Introduction****CAUTION**

This appliance is arranged and tested to operate with G30 gas 50 mbar;

To convert it to another type of gas, follow the instructions in E.7.6 *Conversion to another type of gas* paragraph of this section.

**E.7.2 Fume exhaust**

- "A1" type appliances have to be positioned under an extraction hood to ensure removal of fumes and steam produced by cooking;

**E.7.3 Before connecting**

1. Make sure the appliance is arranged for the type of gas to be used.  
Otherwise, carefully follow the instructions given in E.7.6 *Conversion to another type of gas* paragraph of this section.
2. Fit a rapid gas shutoff tap/valve ahead of each appliance.

3. Install the tap/valve in an easily accessed place.

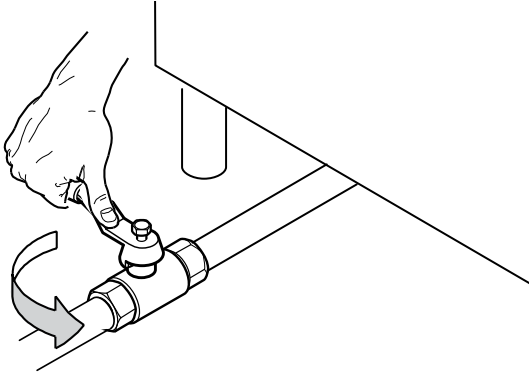

4. Clean the pipes to remove any dust, dirt or foreign matter which could block the supply.  
The gas supply line must ensure the gas flow necessary for full operation of all the appliances connected to the system.  
A supply line with insufficient flow will affect correct operation of the appliances connected to it.



**IMPORTANT**

Incorrect levelling of the appliance can affect combustion and cause malfunctioning.

**E.7.4 Connection (depending on the appliance and/or model)**

**Monoblock models**

1. See the installation diagram for the position of the gas connection on the bottom of the appliance.
2. Remove the plastic cap protection (if present) from the gas manifold before connecting.

**Countertop models (Only for N9E range)**

1. See the installation diagram for the position of the gas connection on the bottom of the appliance.
2. Remove the plastic cap protection (if present) from the gas manifold before connecting.
3. Countertop models can be connected to the gas supply also using the rear connection:
  - a. operate at the back appliance;
  - b. unscrew the metal closing plug of the rear connection;
  - c. screw it tightly onto the bottom connection.

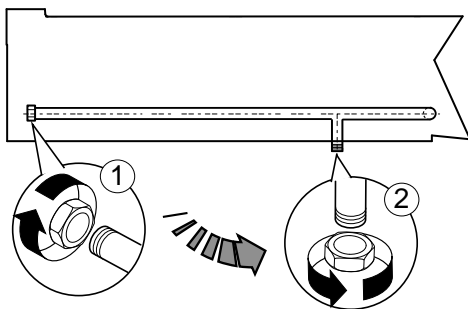

After installation, use soapy water to check connections for leaks.

**E.7.5 Gas pressure regulator**

The section of the gas supply line must be sufficient to ensure the gas flow necessary for full operation of all the appliances connected to the system.

If the gas pressure is higher than that specified or is difficult to regulate (not stable), install a gas pressure regulator (accessory code 927225) in an easily accessed position ahead of the appliance.

The pressure regulator should preferably be fitted horizontally, to ensure the right outlet pressure.

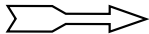
The arrow on the regulator  indicates the gas flow direction.

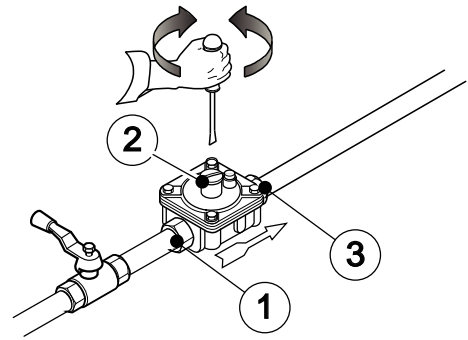

- |   |   |
|---|---|
| 1 | connection side gas from mains            |
| 2 | pressure regulator                        |
| 3 | connection side gas towards the appliance |

**E.7.6 Conversion to another type of gas**

Nozzle Table "B" (see Appendix) gives the type of nozzles to be used when replacing those installed by the manufacturer (the number is engraved on the nozzle body).

At the end of the procedure, carry out the following check-list:

1. burner nozzle/s replacement
2. correct adjustment of primary air supply to burner/s
3. pilot nozzle/s replacement
4. minimum flame screw/s replacement
5. correct adjustment pilot/s if necessary
6. correct adjustment of supply pressure (see technical data/gas nozzles table)
7. apply sticker (supplied) with data of new gas type used

**E.8 Gas appliances regulations**

**E.8.1 Supply pressure check**

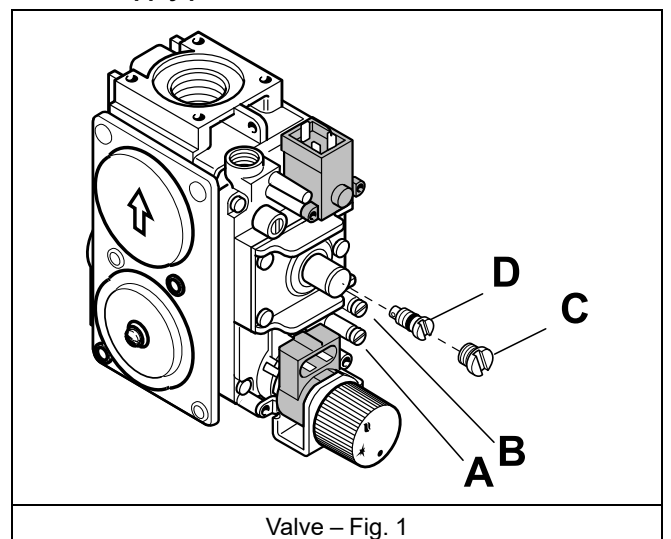

Make sure the appliance is suitable for the type of gas available, according to that given on the dataplate (otherwise, follow the instructions given in E.7.6 *Conversion to another type of gas* paragraph of this section).

The supply pressure must be measured while the appliance operates, using a manometer (min. 0.1 mbar).

See fig. 1.

1. Remove the control panel and retaining screw "A" from the pressure point;
2. Connect a manometer to the pressure point;

- Compare the value read on the manometer with that given in Table "B" (see Appendix);  
If the manometer gives a reading outside the range of values in Table "B" (see Appendix), do not switch the appliance on;  
Consult the gas company.

### E.8.2 Primary air checking

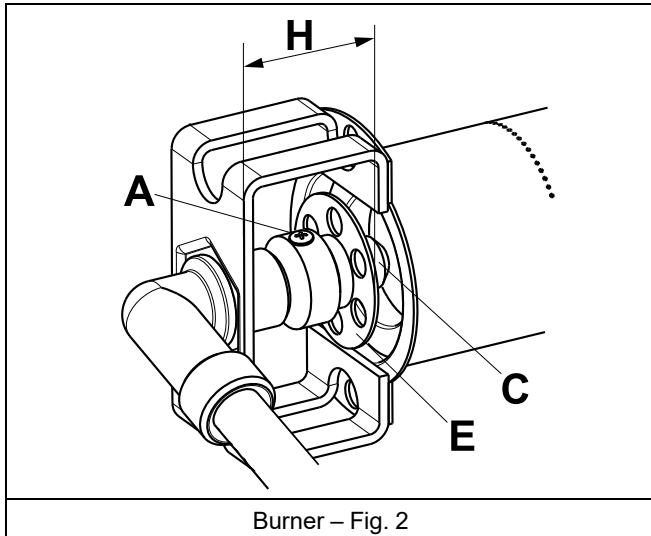

The primary air is correctly adjusted when the flame does not float with the burner cold and there is no flareback with the burner hot.

See fig. 2.

- Undo screw "A";
- Position aerator "E" at distance "H" given in Table "B" (see Appendix);
- Retighten screw "A";
- Seal with paint.

### E.8.3 Replacing the main burner nozzle

See fig. 2.

- Loosen nut "A";
- Unscrew nozzle "C" and the aerator "E";
- Replace nozzle "C" with one suitable for the type of gas, according to that given in table "B" (see Appendix);  
The nozzle diameter is given in hundredths of mm on the nozzle body.
- Insert nozzle "C" into aerator "E".
- Fit the resulting assembly into its location.
- Fully retighten nozzle "C".

### E.8.4 Pilot burner nozzle replacement

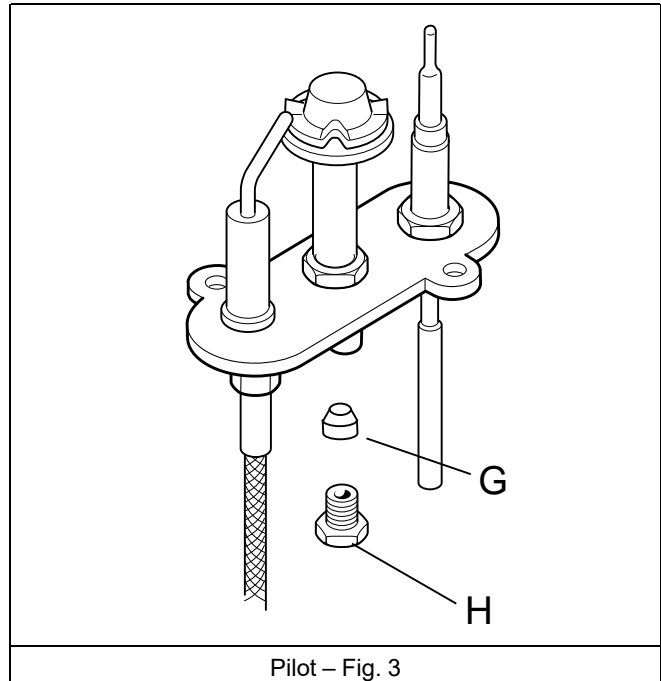

See fig. 3.

- Undo screw coupling "H";
- Replace nozzle "G" with one suitable for the type of gas (see table "B", Appendix);  
The nozzle identification number is indicated on nozzle body.
- Retighten screw coupling "H".

### E.9 Before completing the installation operations

- Use soapy water to check all gas connections for leaks.
- DO NOT use an open flame to check for gas leaks.
- Light all the burners separately and also together, to check correct operation of the gas valves, rings and lighting.
- For each burner, adjust the flame regulator to the lowest setting, individually and together.
- After completing the operations, the installer must instruct the user on the correct method of use.

If the appliance does not work properly after carrying out all the checks, contact the local Customer Care service centre.

### E.10 Automatic filling pans

Connect the inlet pipe for automatic water filling in cavity "H/S1" to a deionized water supply system or, in alternative, to an osmotized water supply system.

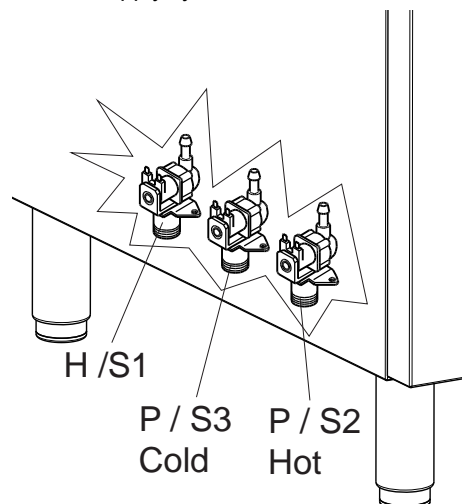

## E.11 Electrical connections

### E.11.1 To access the terminal block

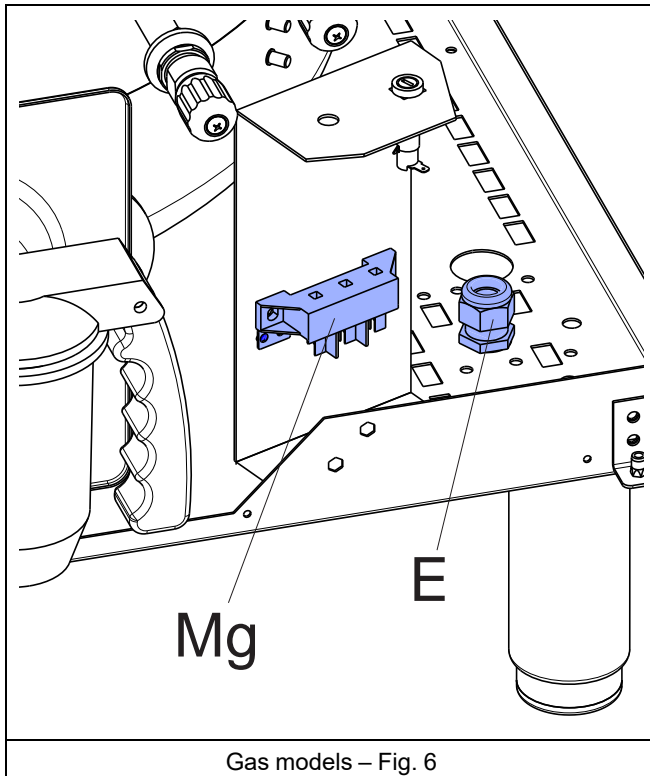

See Fig. 6.

1. Remove the appliance front panel by undoing the fixing screws;
2. connect the power cable to the terminal block "Mg", according to the wiring diagram provided with the appliance;
3. Secure the power cable with the cable clamp "E".



#### IMPORTANT

The manufacturer declines any liability if the safety regulations are not respected.

## E.12 Power cable

Unless otherwise specified, our appliances are not equipped with a power cable.

The installer must use a flexible cable having characteristics not lower than the H07RN-F rubber insulated type.

Protect the section of cable outside the appliance with a metal or rigid plastic tube.



### WARNING

If the power cable is damaged, it must be replaced by the after-sales service or in any case by qualified personnel, in order prevent any risk



### WARNING

The manufacturer declines any liability for damage or injury resulting from breach of the above rules or non-compliance with the electric safety regulation in force in the country where the machine is used

## E.13 Safety thermostat

Appliances equipped with safety thermostat (overheating safety thermostat) that cuts in automatically when temperatures exceed a set value, shutting off the gas supply (gas appliances) or the electricity (electric appliances).



#### IMPORTANT

Resetting of the safety thermostat must be carried out by specialised personnel; contact the Customer Care.



#### IMPORTANT

"Positive trip" effect safety thermostat (used on some equipment type as per norms prescriptions) interrupts the unit operability (heating) even in case the capillary is cut.

Similar effect, but with no damage for the safety thermostat, can happen if the machine body temperature drops below -10°C: in such cases, it is required to reset the safety thermostat while installing the machine, hence before connecting it to the mains.



#### IMPORTANT

On electric heated machines, only reset safety thermostat after disconnecting from the mains. Failure to disconnect from the mains causes the safety thermostat to brake and the unskilled person to risk electrocution.

Tampering with the safety thermostat invalidates the original manufacturer warranty.

### E.13.1 Activation

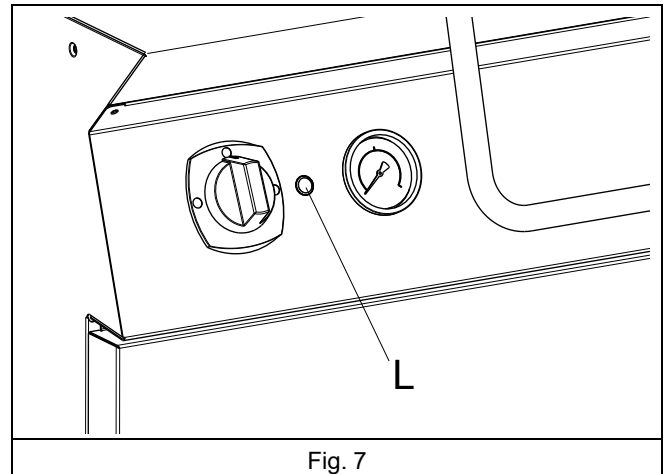

If the limiter in the pots trips and the indicator "L" on the control panel illuminates, it could be the case of an incorrect use. Verify if:

1. the appliance is used empty,
2. the cavity has a low water level,
3. a malfunction occurs.



#### NOTE!

If the limiter trips anyway, contact the Customer Care.

### E.13.2 Resetting

The limiter is reset automatically when the appliance cools down.

### E.13.3 Devices for pressure control (indirect versions only)

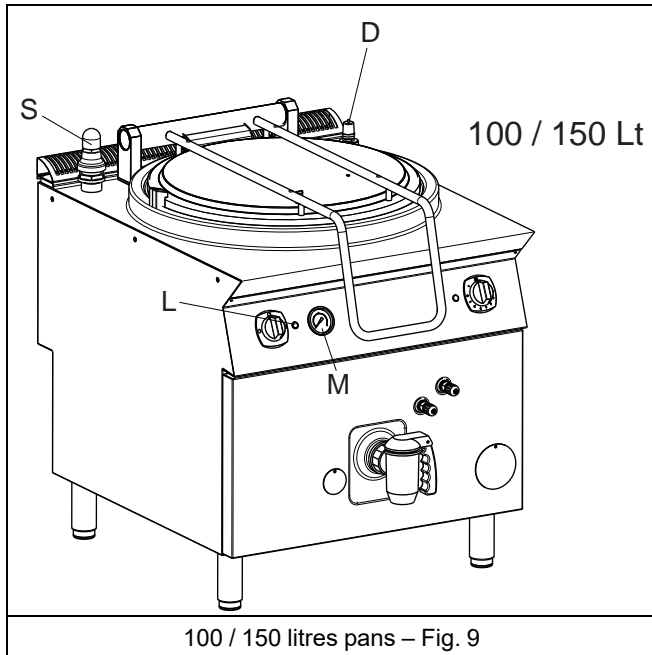
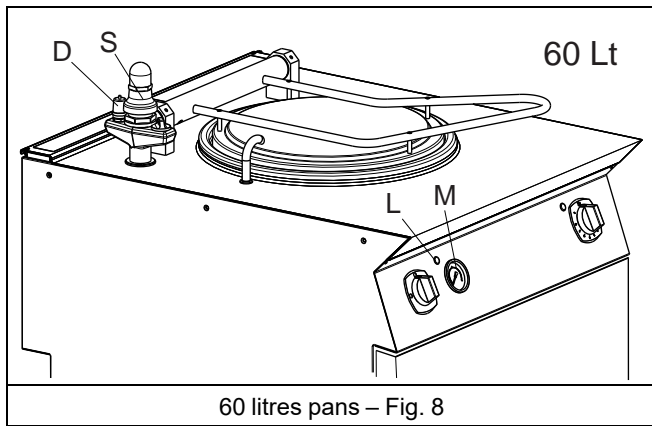

#### 60 / 100 / 150 litres

See Fig. 8 and 9.

1. Pressure gauge "M": indicates the steam pressure inside the cavity;
2. Vacuum relief valve "D": regulates the pressure inside the cavity, guaranteeing the release of air during heating; it also allows air into the cavity during cooling when the pressure tends to fall below the atmospheric value;
3. Safety valve "S": cuts in, releasing steam from the cavity to the outside when the pressure value approaches 0.5 bar.

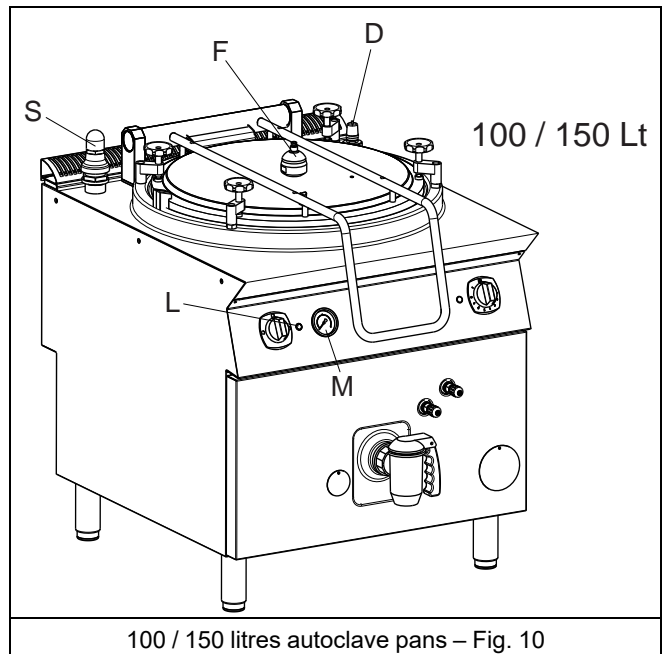

#### 100 / 150 litres autoclave

See Fig. 10.

1. Container steam discharge valve "F" (see Fig. 10): fitted on the lid, it cuts in when the pressure approaches 0.5 bar inside the container; it also allows air into the container when the pressure tends to fall below the atmospheric value (e.g. during cooling with lid closed).

### E.14 Water connection



#### IMPORTANT

- Carry out the water connection by referring to paragraph A.11 *Water connection*.
- If the water pressure is higher than that specified, use a pressure reducer to avoid damaging the appliance.

For correct installation, the water inlet pipe must be connected to the mains using a mechanical filter and a shutoff valve.

Before connecting the filter, allow a certain amount of water to run in order to clear the pipe of any waste matter.

### E.15 Water drain

The discharge water must be removed by means of a suitable receptacle resistant to a temperature of at least 100°C. The steam produced during the discharge stages must not come into contact with the appliance.



#### WARNING

An air-break to drain, conforms to "EN61770", shall be installed before the discharge to the drainage system for both floor drainage and wall drainage, depending on the model.

Floor discharge

Wall discharge

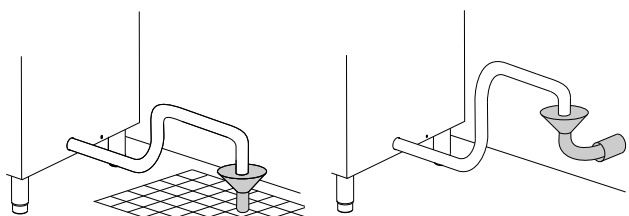

## F NORMAL APPLIANCE USE



### WARNING

Refer to “Warning and Safety Information”.

#### F.1 Characteristics of personnel enabled to operate on the appliance

The Customer must make sure the personnel for normal appliance use are adequately trained and skilled in their duties. The operator must:

- read and understand the manual;
- receive adequate training and instruction for their duties in order to operate safely;
- receive specific training for correct appliance use.



### IMPORTANT

The Customer must make sure his personnel have understood the instructions received and in particular those regarding work hygiene and safety in use of the appliance.

#### F.2 Basic requirements for appliance use

- Knowledge of the technology and specific experience in operating the appliance.
- Adequate general basic education and technical knowledge for reading and understanding the contents of the manual, including correct interpretation of the drawings, signs and pictograms.
- Sufficient technical knowledge for safely performing his duties as specified in the manual.
- Knowledge of the regulations on work hygiene and safety.

## G INSTRUCTION FOR THE USER

#### G.1 General precautions

- The appliance is intended for industrial use by trained personnel.
- This appliance must only be used for its expressly designed purpose; i. e. for cooking or preparing foods in a watery medium. Any other use is deemed improper.
- Never use coarse kitchen salt as this, slowly dissolving, could cause corrosion of the bottom of the tank. Therefore it is advisable to use fine salt (grains smaller than 3 mm) adding it to the water only when boiling. If the salt available is coarse, dissolve it first in warm water in a separate container.



### WARNING

Operating the appliance without water in the cavity causes serious damage due to overheating of the s/steel container and the internal parts.

#### G.2 Water filling

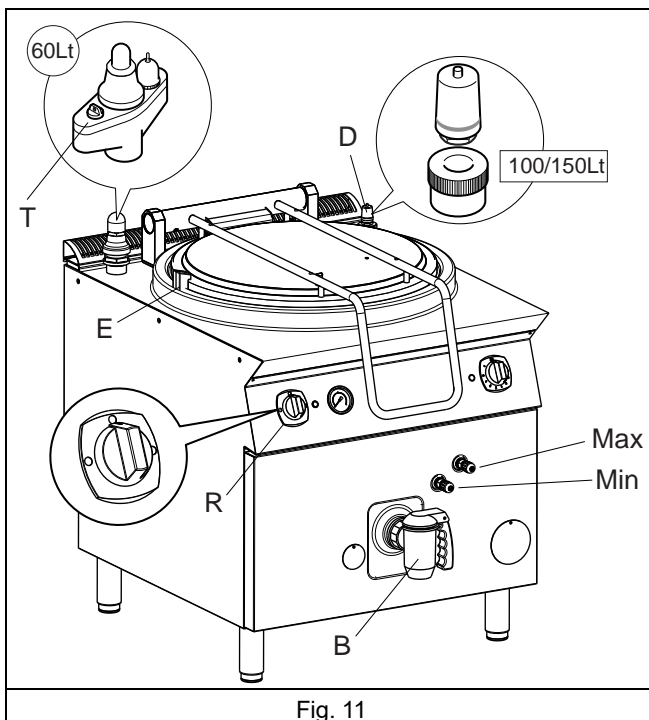

Fig. 11

See Fig. 11.

1. Turn on the automatic switch installed ahead of the appliance and open the water tap;
2. close the drain valve “B”;
3. open the pan lid;
4. rotate the knob “R” to fill the boiling pan:
  - Blue: add cold water;
  - Red: add hot water;
5. The water will come out from dispenser “E”.

#### G.3 Cavity water filling (indirect versions only)



### IMPORTANT

To fill the cavity, only use demineralized water with the addition of corrosion inhibitor (1 packet for 60-litre pans, 2 packets for 100- and 150-litre pans).

##### G.3.1 Automatic filling pans (if present)

See Fig. 11.

1. When the appliance is switched on, the control of the water level inside the cavity and possible automatic filling is activated; without a minimum level of water in the cavity, appliance heating will not switch on until the level is restored.
2. With first use, automatic water filling takes about 30 minutes to bring the water in the cavity to the minimum level. During water filling, add the corrosion inhibitor by means of vent valve “D”.



### IMPORTANT

If the pan does not switch on, have a specialised personnel check the connection to the water supply and the level control system.



### IMPORTANT

For quicker water filling with first use, it is possible to proceed manually through vent valve “D”.

##### G.3.2 Manual filling pans

With the appliance cold, periodically check the water level inside the cavity by means of the two minimum (“Min”) and maximum (“Max”) taps located on the front panel. If water does not come out when operating the “Min” tap, immediately fill the cavity with water (see Fig. 11).

- Remove vent valve “D” by unscrewing the nut at the bottom (for 100- and 150 litre pans) or unscrew cap “T” (for 60 litre pans)



## WARNING

Do not operate when the appliance is on or still hot

- Open maximum tap "Max" (see Fig. 7);
- Pour demineralized water through the filler hole up to the maximum level (corresponding to water coming out the maximum tap).
- Close maximum tap "Max".
- Carefully retighten vent valve "D" or cap "T" .

### G.4 Pressure switch (indirect versions only)

The pressure switch maintains an optimum pressure inside the cavity, stopping the heating when the set pressure value is exceeded. This offers energy-saving and a reduction in cavity water consumption

### G.5 Gas models

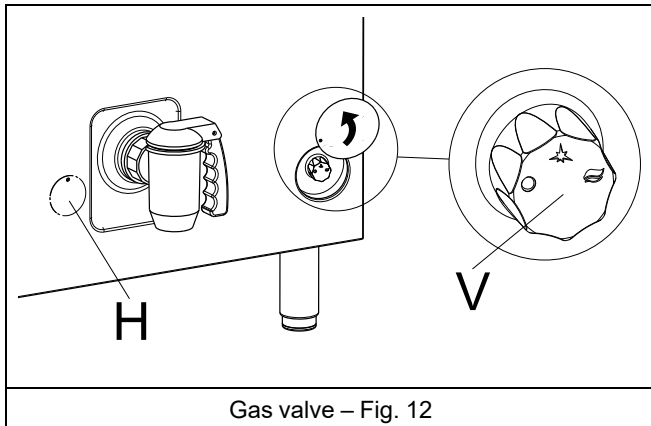

The burner igniter knob "V" has 3 positions (see Fig. 12):

●	"Off"
★	"Pilot ignition"
🔥	"On"

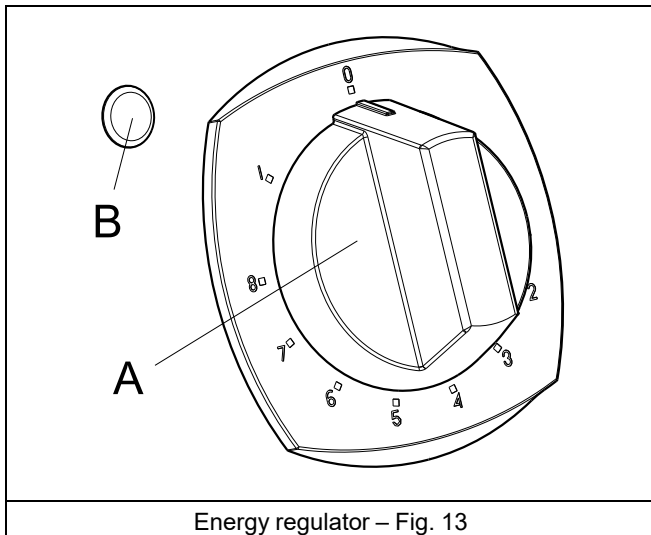

The switch and regulator knob "A" on the front panel has 4 positions (see Fig. 13):

0	"Tank heating off"
1...5	"Low-medium power"
6...8	"Medium-high power"
I	"Maximum power"

The green indicator "B" signals that the power is on.

### Lighting on

1. Turn the regulator knob "A" to "1" to switch on the appliance (see Fig. 13).
2. Press and turn knob "V" to "Pilot ignition" position (see Fig. 12).
3. Press the knob "V" down fully to activate the electric igniter and light the pilot.
4. Release the knob "V" a little to deactivate lighting, keeping it lightly pressed for about 20 seconds; when released, the pilot flame must stay alight. If it does not, repeat the operation.
5. Turn the knob "V" to "On" position.
6. Turn the regulator knob "A" to select the required cooking power (see Fig. 13).



### IMPORTANT

In case of emergency, the pilot burner can be lit manually by bringing a flame to it through hole "H" (see Fig. 8) and keeping knob "V" pressed in the "Pilot ignition" position.

### Switching off

1. Partially press knob "V" and turn it "Pilot ignition" position to keep the pilot flame lit for subsequent cooking (see Fig. 12);
2. Partially press knob "V" and turn it to "Off".
3. Turn the regulator knob "A" to "Off" (see Fig. 13).

### G.5.1 Safety thermostat

The gas valve has a safety device which prevents immediate (for about 60 seconds) re-lighting if the pilot burner goes out. This ensures the flow of any gas accumulated, and better safety.

### G.6 Energy saving



### IMPORTANT

The choice of a different power level from "I" involves turning heating off and on again. This guarantees energy-saving without compromising cooking (see Fig. 13)

1. **Indirect version:** each time the appliance is switched on, after 10-15 minutes discharge the air from the cavity by pressing vent valve "D" (see Fig. 10). This guarantees an optimum pressure inside the cavity (better cooking and energy-saving), releasing the air inside.

### G.7 At the end of the service

1. Empty and clean the pan by opening the drain valve "B" (see Fig. 7).



### IMPORTANT

To reduce wear and prevent the breakage of the drain valve "B" lubricate it once a week using food fats.

## H APPLIANCE CLEANING AND MAINTENANCE



## WARNING

Refer to "Warning and Safety Information".

### H.1 Care information

Care operations have to be carried out by the owner and/or user of the appliance.

**IMPORTANT**

Problems resulting from poor or lack of care as hereinafter described will not be covered by the warranty.

After use the cooking plate is very hot; always wait at least 15 minutes before cooling down with water or ice, in order to avoid the permanent deform of the cooking plate and compromise of appliance operation.

**H.2 Informations for maintenance**

Routine maintenance operations can be carried out by non-specialised personnel, carefully following the instructions given below.

**NOTE!**

The manufacturer declines any liability for operations carried out on the machine without following these instructions.

**CAUTION**

Before carrying out any cleaning operation, disconnect the appliance from the power supply.

**IMPORTANT**

Pay attention to the selection and use of cleaning products in order to maintain proper appliance performance and safeness.

**H.3 Maintenance intervals**

It is advisable to carry out the checks with the frequency given in the following table:

Maintenance, inspections, checks and cleaning	Frequency	Responsibility
Ordinary cleaning • general cleaning of appliance and surrounding area	• Daily	• Operator
Mechanical protection devices • check their condition and for any deformation, loosening or removed parts	• Every 6 months	• Service
Control • check the mechanical parts, for cracks or deformations, tightening of screws: check the readability and condition of words, stickers and symbols and restore if necessary	• Yearly	• Service
Appliance structure • tightening of main bolts (screws, fixing systems, etc.) of appliance	• Yearly	• Service
Safety signs • check the readability and condition of safety signs	• Yearly	• Service
Electrical control panel • check the electrical components installed inside the electrical control panel. Check the wiring between the electrical panel and appliance parts	• Yearly	• Service
Electrical connection cable • check the connection cable (replace if necessary)	• Yearly	• Service
General appliance overhaul • check all components, electrical equipment, corrosion, pipes...	Every 10 years <sup>1</sup>	• Service

1. The appliance is designed and built for a duration of about 10 years. After this period of time (from commissioning) the appliance must undergo a general inspection and overhaul.

**H.4 Periods of non-use**

If the appliance is not going to be used for some time, take the following precautions:

- close the water supply tap(s), if present;
- close the gas valves;
- disconnect the power supply or remove the plug from the power socket, if present;
- clean the cabinet, going over all the stainless steel surfaces vigorously with a rag moistened with paraffin oil to create a protective film;
- leave the door or drawers, if present, open so that air can circulate inside, preventing the formation of unpleasant odours;
- for the electric heated models: switch on the appliance at the minimum rate of heat for at least 45 minutes; this will

allow moisture/humidity accumulated into the heating elements to evaporate without damaging the elements;

- periodically air the premises.

**H.5 External parts****SATIN-FINISH STEEL SURFACES (daily)**

- Clean all steel surfaces: dirt is easily removed when it has just formed.
- Remove grime, fat and other cooking residuals from steel surfaces when cool using soapy water, with or without detergent, and a cloth or sponge.  
Dry the surfaces thoroughly after cleaning.
- In case of encrusted grime, fat or food residuals, go over with a cloth or sponge, wipe in the direction of the satin finish and rinse often:

Rubbing in a circular motion combined with the particles of dirt on the cloth/sponge could spoil the steel's satin finish.

- Metal objects can spoil or damage the steel: damaged surfaces become dirty more easily and are more subject to corrosion.
- Restore the satin finish if necessary.

#### **SURFACES BLACKENED BY HEAT (when necessary)**

- Exposure to high temperatures can cause the formation of dark marks.

These do not constitute damage and can be removed by following the instructions given in the previous section.

### **H.6 Other surfaces**

#### **Automatic filling system (every 6 months)**

- Check the system and probes, if necessary removing any deposits using pure vinegar or a solution of chemical detergent (1/3) and water (2/3). This operation must be carried out by specialised personnel.

#### **Heated tanks/containers (daily)**

- Clean the appliance tanks or containers using boiled water, adding soda (degreasing) if necessary. Use the accessories (optional or supplied) specified in the list to eliminate encrustations or food deposits.



#### **CAUTION**

With electric appliances, make sure no water comes into contact with electrical components: water penetration can cause short circuiting and dissipation, tripping the appliance's protection devices.

### **H.7 Scale**

#### **Steel surfaces (when necessary)**

- Remove any scale (stains or marks) left by water on steel surfaces using suitable natural detergents (e.g. vinegar) or chemical.

#### **Boilers or cavities (every 3–4 months)**

- Descale the devices used for holding and heating of water (e.g. cavities of indirect pans) by filling them with pure vinegar or a solution of chemical detergent (1/3) and water (2/3).

#### **Vinegar**

- Heat for about 5 minutes.
- Allow the vinegar to work for at least 20 minutes.
- Rinse with plenty of demineralised water.

#### **Chemical detergent**

- Heat for about 3 minutes.
- Allow the solution to work for at least 10 minutes.
- Rinse with plenty of demineralised water.

### **H.8 Internal parts (every 6 months)**



#### **IMPORTANT**

Operations to be carried out only by specialised personnel.

- Check the condition of the internal parts.
- Remove any deposits of dirt inside the appliance.
- Check and clean the discharge system.



#### **IMPORTANT**

In particular conditions (e.g. intensive use of the appliance, salty environment, etc.) the above cleaning should be more frequent.

### **H.9 Spout greasing**

- At the end of each day disassemble the internal part of the spout, remove any food residuals, and grease the conical surface with KluberNontrop-PLB DR grease.

## **I TROUBLESHOOTING**

### **I.1 Introduction**

Certain faults may occur during normal use of the appliance. In some cases, faults can be eliminated easily and quickly by following the indication below.

#### **If the fault persists, contact the Customer Care Service:**

1. Disconnect the appliance from the main power supply;
2. Switch off the safety circuit breaker ahead of the appliance;
3. Close the gas and water tap(s), if they are present;

4. Remember to specify:
  - the type of fault
  - the appliance PNC (product number code)
  - the Ser. No. (appliance serial number).



#### **IMPORTANT**

The appliance PNC and serial number are essential for identifying the type of appliance and date of manufacture.

### **I.2 Brief Troubleshooting guide**

<b>Malfunction</b>	<b>Possible causes</b>	<b>Actions</b>
<b>The pilot burner does not light.</b>	<ul style="list-style-type: none"> <li>• The igniter is not properly fixed or connected.</li> <li>• The ignition or igniter cable are damaged.</li> <li>• Insufficient pressure in gas pipes.</li> <li>• Blocked nozzle.</li> <li>• Faulty gas valve.</li> </ul>	<ul style="list-style-type: none"> <li>• Call Service.</li> <li>• Switch on the Pilot Burner with an external flame / Contact service</li> <li>• Check the gas connection and verify the gas supply</li> <li>• Call service.</li> <li>• Call service.</li> </ul>

<b>The pilot burner goes out.</b>	<ul style="list-style-type: none"> <li>• The pilot burner is not heating the thermocouple sufficiently.</li> <li>• The gas valve knob is not being pressed enough.</li> <li>• Lack of gas pressure at the valve.</li> <li>• Faulty gas valve.</li> </ul>	Call service.
<b>The main burner does not light</b>	<ul style="list-style-type: none"> <li>• Loss of pressure in gas pipe.</li> <li>• Blocked nozzle or faulty gas valve.</li> <li>• Burner with gas outlet holes clogged.</li> </ul>	Call service.

## J APPLIANCE DISPOSAL



### WARNING

Refer to “*Warning and Safety Information*”.

#### J.1 Procedure regarding appliance disposal

At the end of the product's life-cycle, make sure it is not dispersed in the environment.

Different regulations are in force in the various countries, therefore comply with the provisions of the laws and competent bodies in the country where appliance disposal takes place.

The appliance's parts must be disposed of in a differentiated way, according to their different characteristics (e. g. metals, oils, greases, plastic, rubber, etc.).

Before disposing of the appliance, make sure to carefully check its physical condition, and in particular any parts of the structure that can give or break during dismantling.

Depending on the model, the doors must be removed before dismantling the appliance.



The symbol on the product indicates that this product should not be treated as domestic waste, but must be correctly disposed of in order to prevent any negative consequences for the environment and human health. For further information on the recycling of this product, contact the local dealer or agent, the Customer Care service or the local body responsible for waste disposal.



#### NOTE!

When dismantling the appliance, any marking, this manual and other documents concerning the appliance must be destroyed.





CE